



**Fusionsolar**

Smart String ESS Solution

[SOLAR.HUAWEI.COM](http://SOLAR.HUAWEI.COM)





HUAWEI

## About Huawei

Huawei is a leading global provider of information and communications technology (ICT) infrastructure and smart devices. With integrated solutions across four key domains – telecom networks, IT, smart devices, and cloud services – we are committed to bringing digital to every person, home and organization for a fully connected, intelligent world. Huawei's end-to-end portfolio of products, solutions and services are both competitive and secure. Through open collaboration with ecosystem partners, we create lasting value for our customers, working to empower people, enrich home life, and inspire innovation in organizations of all shapes and sizes. At Huawei, innovation focuses on customer needs. We invest heavily in basic research, concentrating on technological breakthroughs that drive the world forward.



Employees

207,000+



R&D Personnel

55%



Countries

170+



Best Global Brands

92



R&D Investment

5



Most Innovative Companies

8

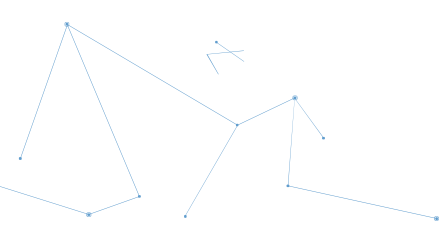

# FusionSolar Smart String ESS Solution

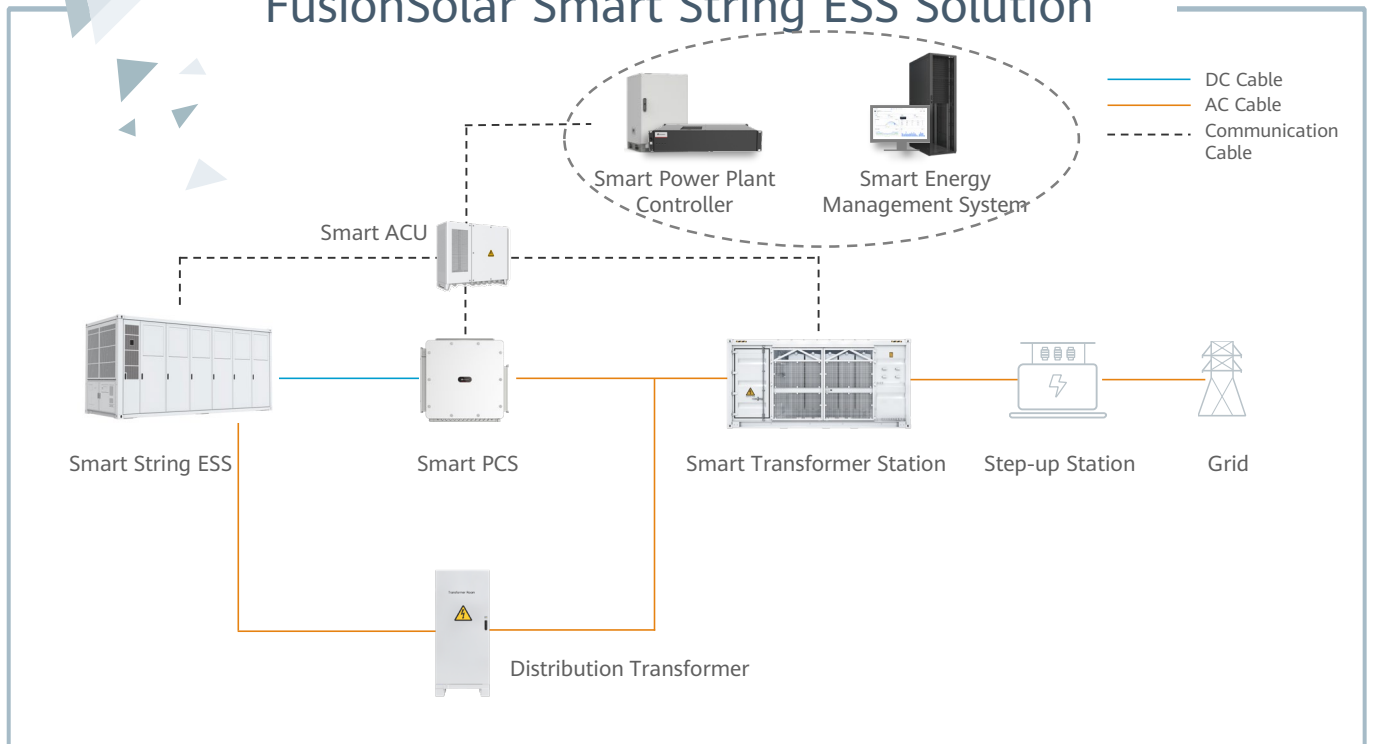

Ultra Safety

Native Stability

Higher Revenue

All-round Smart Mgmt.



# Model: LUNA2000-4472-2S

## Smart String ESS



**All-architecture  
Safety**



**All-scenario  
Grid forming**



**All-lifecycle  
Cost-effectiveness**



**All-rounder  
Digitalization**

### Battery Container

Model	LUNA2000-4472-2S
DC Rated Voltage	1,331.2 V
DC Max. Voltage	1,500 V
Nominal Energy Capacity	4,472 kWh
Charge & Discharge Rate	≤ 0.5 C
Rated Power	2,236 kW
Dimension (W x H x D)	6,058 x 2,896 x 2,438 mm
Weight	≤ 42 t
Operation Temperature Range	-30° C ~ 55° C
Storage Temperature Range	-40° C ~ 60° C
Relative Humidity	0 ~ 100% (Non-condensing)
Max. Operating Altitude	4,700 m
Cooling Method	Liquid Cooling
Fire Suppression System	Water Sprinkler, NOVEC 1230 (Optional)
Communication Interface	Ethernet / SFP
Communication Protocol	Modbus TCP
Protection Degree	IP55
Anti-corrosion Degree	C5-Medium

### Standards Compliance

RoHS, IEC62477-1, IEC62040-1, IEC61000-6-2, IEC62933-5-2, UL9540A, IEC62619, UN38.3, etc.

### Battery Pack

Cell Material	LFP
Number of Cell	104
Nominal Capacity	280 Ah / 93.18 kWh
Protection Degree	IP65
Weight	670 ± 10 kg
Dimensions (W x H x D)	785 x 249 x 2182 mm

# Model: LUNA2000-2.0MWH Series Smart String ESS



**All-architecture  
Safety**



**All-scenario  
Grid forming**



**All-lifecycle  
Cost-effectiveness**



**All-rounder  
Digitalization**

Battery Container			
Model	LUNA2000-2.0MWH-4H1	LUNA2000-2.0MWH-2H1	LUNA2000-2.0MWH-1H1
DC Rated Voltage		1,250 V	
DC Max. Voltage		1,500 V	
Nominal Energy Capacity		2,032 kWh	
Charge & Discharge Rate	≤ 0.25 C	≤ 0.5 C	≤ 1 C
Rated Power	508 kW	1,016 kW	2,032 kW
Container Configuration (W x H x D)		6,058 x 2,896 x 2,438 mm	
Container Weight		≤ 30 t	
Operation Temperature Range		-30°C ~ 55°C	
Storage Temperature Range		-40°C ~ 60°C	
Relative Humidity		0 ~ 100% (Non-condensing)	
Max. Operating Altitude		4,000 m	
Cooling Method		Smart Air Cooling	
Configuration of HVAC	2 HVACs	4 HVACs	6 HVACs
Fire Suppression System		Novec 1230™ + Water Sprinkler	
Communication Interface		Ethernet / SFP	
Communication Protocol		Modbus TCP / IEC 104	
Protection Degree		IP55	
Anti-corrosion Protection		C5-Medium	
Low Voltage AC Coupling	Yes	Yes	Yes
Grid Forming	Yes	Yes	Yes
Standards Compliance			
RoHS, IEC62477-1, IEC62040-1, IEC61000-6-2, EN55011, UL9540A, IEC62619, UN3536, etc.			

# Model: LUNA2000-1.0MWH-1H1

## Smart String ESS



**All-architecture  
Safety**



**All-scenario  
Grid forming**



**All-lifecycle  
Cost-effectiveness**



**All-rounder  
Digitalization**

### Battery Container

Model	LUNA2000-1.0MWH-1H1
DC Rated Voltage	1,250 V
DC Max. Voltage	1,500 V
Nominal Energy Capacity	1,016 kWh
Rated Power	1,016 kW
Container Configuration (W x H x D)	6,058 x 2,896 x 2,438 mm
Container Weight	≤ 20 t
Operation Temperature Range	-30°C ~ 55°C
Storage Temperature Range	-40°C ~ 60°C
Relative Humidity	0 ~ 100% (Non-condensing)
Max. Operating Altitude	4,000 m
Cooling Method	Smart Air Cooling
Configuration of HVAC	3 HVACs
Fire Suppression System	Novec 1230™ + Water Sprinkler
Communication Interface	Ethernet / SFP
Communication Protocol	Modbus TCP / IEC 104
Protection Degree	IP55
Anti-corrosion Degree	C5-Medium
Black Start	Yes

### Standards Compliance

RoHS, IEC62477-1, IEC62040-1, IEC61000-6-2, EN55011, UL9540A, , IEC62619, UN3536, etc.

# Smart String ESS Battery Pack & Smart Rack Controller



## Battery Pack<sup>1</sup>

### General

Cell Material	LFP
Pack Configuration	18S 1P
Rated Voltage	57.6 V
Nominal Capacity	280 Ah / 16.13 kWh
Supported Charge & Discharge Rate	≤ 1 C
Weight	≤ 140 kg
Dimensions (W x H x D)	442 x 307 x 660 mm



## Smart Rack Controller<sup>1</sup>

### Battery Side

Rated Voltage	1,209.6 V
Operating Voltage Range	40 V ~ 1,400 V
Rated Power Voltage Range	1,075 V ~ 1,320 V
Min. Start Voltage	350 V

### Bus Side

Max. DC Voltage	1,500 V
Rated Voltage	1,250 V
Rated Current	275.2 A
Rated Power	344,000 W

### General

Dimensions (W x H x D)	600 x 270 x 820 mm
Weight	≤ 90 kg
Cooling Method	Smart Air Cooling
Protection Degree	IP66

1 - Applies to LUNA2000-2.0MWH / 1.0MWH series models.

# Model: LUNA2000-213KTL-H0

## Smart PCS



**Max. Efficiency 99%**



**Modular Design**



**IP66 Protection**



**Built-in Intelligent Active Breaking Device**



**Dual-stage Architecture**



**Smart Grid Forming Algorithm**

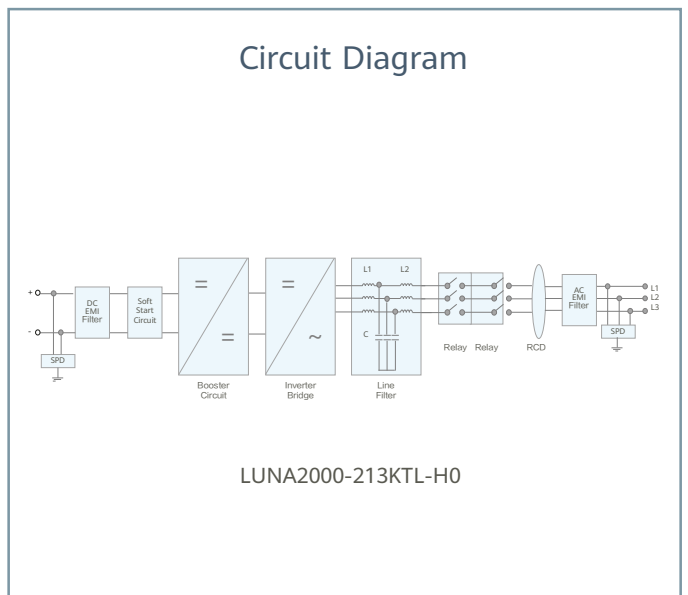



Model: LUNA2000-213KTL-H0  
**Technical Specifications**

Efficiency	
Max. Efficiency	99.01%
DC Side	
Rated DC Voltage	1,331 V
Max. DC Voltage	1,500 V
Operating DC Voltage Range	800 V ~ 1,500 V
Rated Power Operating Voltage Range	1100V-1500V
Max. DC Current	218.5 A
Max. Number of Inputs	1
AC Side	
Rated AC Active Power	213,000 W @40°C; 192,000 W @50°C
Max. Apparent Power	236,400 VA
Rated AC Voltage	800 V
Rated AC Grid Frequency	50 Hz / 60 Hz
Max. AC Current	170.6 A
Adjustable Power Factor Range	-1 ... +1
Max. Total Harmonic Distortion	THD <sub>i</sub> ≤ 1.5% (Rated)
Protection	
AC Overcurrent Protection	Yes
DC Reverse-polarity Protection	Yes
Insulation Resistance Detection	Yes
Residual Current Protection	Yes
DC Surge Protection	Type II
AC Surge Protection	Type II
Communication	
Display	LED Indicators, WLAN + APP
USB	Yes
Communication Protocol	Ethernet, CAN
General	
Dimension (W x H x D)	875 x 865 x 365 mm
Weight	≤ 110 kg
Operating Temperature Range	-25°C ~ 60°C
Cooling Method	Smart Air Cooling
Max. Operating Altitude without Derating	4,700 m
Relative Humidity	0 ~ 100% (Non-condensing)
DC Connector	OT / DT Terminal
AC Connector	OT / DT Terminal
Protection Degree	IP66
Anti-corrosion Degree	C5-Medium
Topology	Transformerless
Standards Compliance	
GB/T 34120, GB/T 34133, IEC/EN62477-1, etc.	

# Model: LUNA2000-200KTL-H1 Smart PCS



**Max. Efficiency 99%**



**Modular Design**



**IP66 Protection**



**Surge Arresters for  
DC & AC**



**Ethernet  
Communication**



**Smart Grid Forming  
Algorithm**

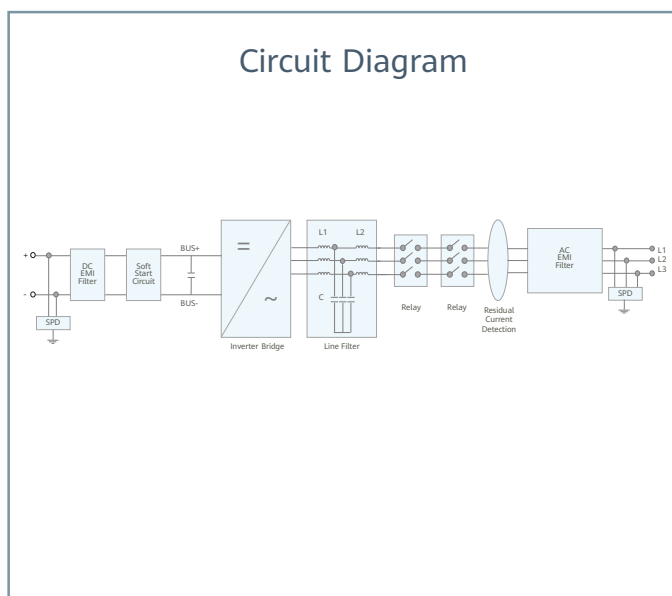
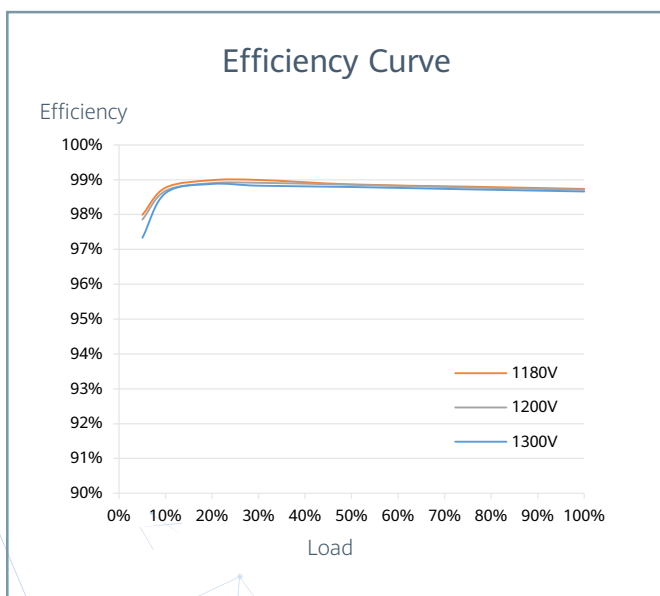

Model: LUNA2000-200KTL-H1  
**Technical Specifications**

Efficiency	
Max. Efficiency	99.01%
DC Side	
Rated DC Voltage	1,180 V
Max. DC Voltage	1,500 V
Operating DC Voltage Range	1,180 V ~ 1,500 V
Max. DC Current	207.6 A
Max. Number of Inputs	1
AC Side	
Rated AC Active Power	200,000 W @40°C
Rated AC Voltage	800 Vac, 3W + PE
Rated AC Grid Frequency	50 Hz / 60 Hz
Max. AC Current	173.2 A
Adjustable Power Factor Range	-1 ... +1
Max. Total Harmonic Distortion	THD <sub>i</sub> < 1% (Rated)
Grid Forming	Yes
Protection	
AC Overcurrent Protection	Yes
DC Reverse-polarity Protection	Yes
Insulation Resistance Detection	Yes
Residual Current Protection	Yes
DC Surge Protection <sup>1</sup>	Type II
AC Surge Protection <sup>1</sup>	Type II
Communication	
Display	LED Indicators, WLAN + APP
USB	Yes
Ethernet	Yes
General	
Dimensions (W x H x D)	875 x 820 x 365 mm
Weight	< 99 kg
Operating Temperature Range	-25°C ~ 60°C
Cooling Method	Smart Air Cooling
Max. Operating Altitude without Derating	4,000 m
Relative Humidity	0 ~ 100% (Non-condensing)
DC Connector	OT / DT Terminal
AC Connector	OT / DT Terminal
Protection Degree	IP66
Anti-corrosion Protection	C5-Medium
Topology	Transformerless
Standards Compliance	
RoHS, IEC 62477-1, IEC 61000-6-2, IEC 61683, VDE 4120, EN 50549, etc.	

1: Compatible Type II protection class according to IEC / EN 61643-11



# Model: JUPITER-9000K-H0 / STS-6000K /3000K-H1 Smart Transformer Station



## Simple

Prefabricated and Pre-tested, No Internal Cabling Needed Onsite  
Compact 20' HC Container Design for Easy Transportation



## Efficient

High Efficiency Transformer for Higher Yields  
Lower Self-consumption for Higher Yields



## Smart

Real-time Detection of Transformer, LV Panel and RMU  
High Precision Sensor of LV Electricity Parameters  
Remote Control of ACB and MV Circuit Breaker



## Reliable

Robust Design against Harsh Environments  
Optimal Cooling Design for High Availability and Easy O&M  
Comprehensive Tests from Components, Device to Solution

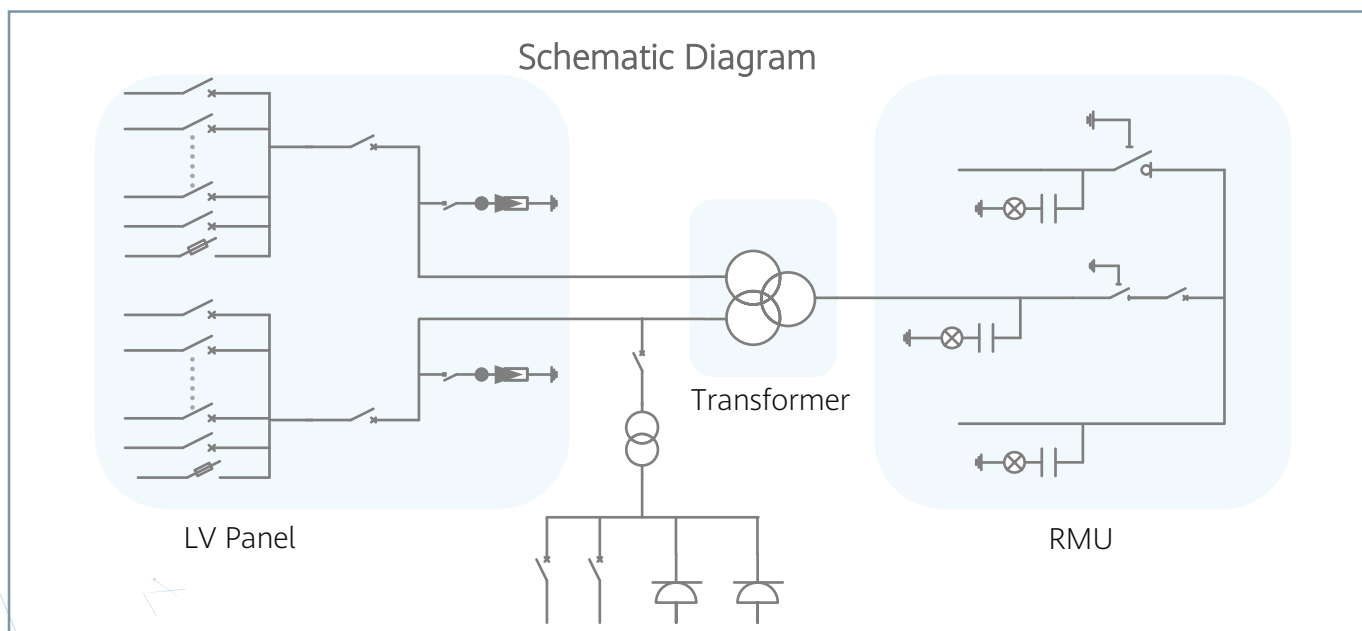

# Technical Specifications

Technical Specifications	JUPITER-9000K-H0	STS-6000K-H1	STS-3000K-H1
<b>Input</b>			
Available Inverters	LUNA2000-213KTL / LUNA2000-200KTL		
Max. LV AC Inputs	44	34	17
AC Power	9,000 kVA @40°C <sup>1</sup>	6,800 kVA @40°C <sup>1</sup>	3,400 kVA @40°C <sup>1</sup>
Rated Input Voltage	800 V		
LV Panel Segregation	Form 2b		
LV Main Switches	ACB (4,000 A, 2 x 1 pcs)	ACB (2,900 A, 2 x 1 pcs)	ACB (2,900 A, 1 pcs)
LV Main Switches for LUNA2000-213KTL / 200KTL	MCCB (250 A, 2 x 22 pcs)	MCCB (250 A, 2 x 17 pcs)	MCCB (250 A, 17 pcs)
<b>Output</b>			
Rated Output Voltage	10~35 kV <sup>2</sup>		
Frequency	50 Hz / 60 Hz		
Transformer Type	Oil-immersed, Conservator Type		
Transformer Cooling Type	ONAN		
Transformer Tappings	± 2 x 2.5%		
Transformer Oil Type	Mineral Oil (PCB Free)		
Transformer Vector Group	Dy11-y11		Dy11
Transformer Min. Peak Efficiency Index	Tier 1 or Tier 2 In Accordance with EN 50588-1		
RMU Type	SF <sub>6</sub> Gas Insulated		
RMU Transformer Protection Unit	MV Vacuum Circuit Breaker Unit		
RMU Cable Incoming / Outgoing Unit	Direct Cable Unit or Cable Load Break Switch Unit		
Auxiliary Transformer	Dry Type Transformer, 5 kVA, Single-phase, li0	Dry Type Transformer, 5 kVA, Three-phase, Dyn11	
Output Voltage of Auxiliary Transformer	230 / 127 Vac	400 / 230 Vac or 220 / 127 Vac	
<b>Protection</b>			
Transformer Detection & Protection	Oil Level, Oil Temperature, Oil Pressure and Buchholz		
Protection Degree of MV & LV Room	IP 54		
Internal Arcing Fault of STS	IAC A 20 kA 1s		
MV Relay Protection	50/51, 50N/51N		
LV Overvoltage Protection	Type I+II		
Anti-rodent Protection	C5-Medium		
<b>Features</b>			
2 kVA UPS	Optional <sup>3</sup>		
MV Surge Arrester for MV VCB	Optional <sup>3</sup>		
<b>General</b>			
Dimensions (W x H x D)	6,058 x 2,896 x 2,438 mm (20' HC ISO Container)		
Weight	< 28 t	< 22 t	< 15 t
Operating Temperature Range	-25°C ~ 60°C <sup>4</sup>		
Relative Humidity	0% ~ 95% (Non-condensing)		
Max. Operating Altitude	1,000 m <sup>5</sup>		
MV-LV AC Connections	Prewired and Pretested, No Internal Cabling Onsite		
LV & MV Room Cooling	Smart Cooling without Air-across for Higher Availability		
Communication	Modbus TCP, Preconfigured with SmartACU2000D	Modbus RTU, Preconfigured with SmartACU2000D	
<b>Standards Compliance</b>			
IEC 62271-202, EN 50588-1, IEC 60076, IEC 62271-200, IEC 61439-1			

1: More detailed AC power of STS, please refer to the de-rating curve.

2: Rated output voltage from 10 kV to 35 kV, more available upon request

3: Extra expense needed for optional features which standard product doesn't contain, more options upon request.

4: When ambient temperature ≥55°C, awning shall be equipped for STS on site by customer.

5: For higher operating altitude, pls consult with Huawei.

# Model: JUPITER-3000K-H1-GF Smart Transformer Station

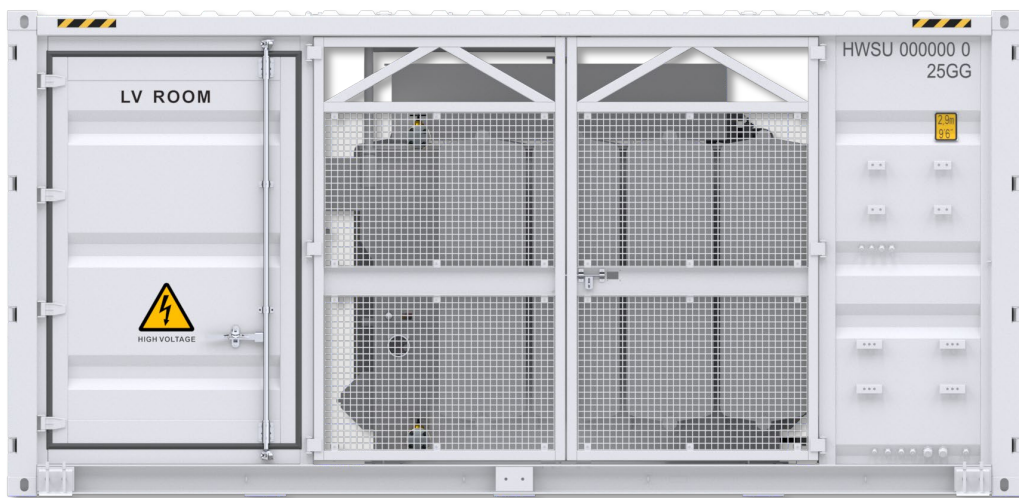

## Simple

Prefabricated and Pre-tested, No Internal Cabling Needed Onsite  
Compact 20' HC Container Design for Easy Transportation



## Efficient

High Efficiency Transformer for Higher Yields  
Lower Self-consumption for Higher Yields



## Smart

Real-time Detection of Transformer, LV Panel and RMU  
High Precision Sensor of LV Electricity Parameters  
Remote Control of ACB and MV Circuit Breaker



## Reliable

Robust Design against Harsh Environments  
Optimal Cooling Design for High Availability and Easy O&M  
Comprehensive Tests from Components, Device to Solution

## Schematic Diagram

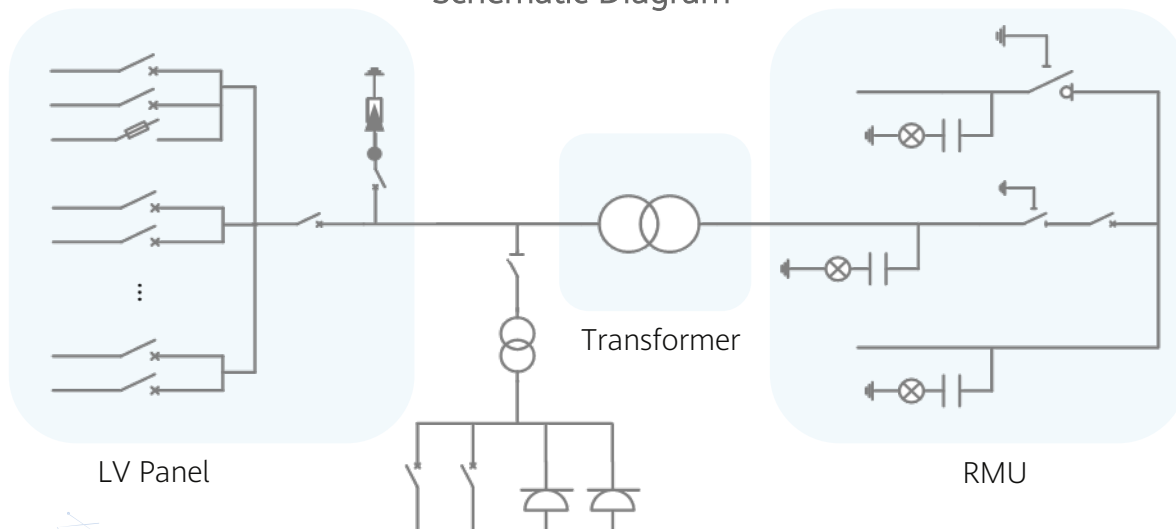

Model: JUPITER-3000K-H1-GF

# Technical Specifications

Input	
Available Inverters / PCS	LUNA2000-200KTL-H1
Maximum LV AC Inputs	37
AC Power	3,300 kVA @40°C / 3,025 kVA @50°C <sup>1</sup>
Rated Input Voltage	800 V
LV Panel Segregation	Form 2b
LV Main Switches	ACB (2,900 A / 800 V / 3P, 1 x 1 pcs)
LV Main Switches for LUNA2000-200KTL-H1	MCCB (250 A / 800 V / 3P, 2 x 18 pcs)
LV Main Switches for DTS-200K-D0	MCCB (250 A / 800 V / 3P, 1 x 1 pcs)
Output	
Rated Output Voltage	30 kV, 33 kV, 35 kV <sup>2</sup>
Frequency	50 Hz
Transformer Type	Oil-immersed, Conservator Type
Transformer Cooling Type	ONAN
Transformer Tappings	± 2 x 2.5%
Transformer Oil Type	Mineral Oil (PCB Free)
Transformer Vector Group	Dy11
Transformer Min. Peak Efficiency Index	Tier 1 or Tier 2 In Accordance with EN 50588-1
RMU Type	SF <sub>6</sub> Gas Insulated
RMU Transformer Protection Unit	MV Vacuum Circuit Breaker Unit
RMU Cable Incoming / Outgoing Unit	Direct Cable Unit or Cable Load Break Switch Unit
Auxiliary Transformer	Dry Type Transformer, 5 kVA, Single-phase, li0
Output Voltage of Auxiliary Transformer	230 / 127 Vac
Protection	
Transformer Detection & Protection	Oil Level, Oil Temperature, Oil Pressure and Buchholz
Protection Degree of MV & LV Room	IP 54
Internal Arcing Fault Classification of STS	IAC A 20 kA 1s
MV Relay Protection	50/51, 50N/51N
LV Overvoltage Protection	Type I+II
Anti-rodent Protection	C5-Medium
Features	
2 kVA UPS	Optional <sup>3</sup>
MV Surge Arrester for Transformer	Optional <sup>3</sup>
General	
Dimensions (W x H x D)	6,058 x 2,896 x 2,438 mm (20' HC ISO Container)
Weight	< 23 t
Operating Temperature Range	-25°C ~ 60°C <sup>4</sup>
Relative Humidity	0% ~ 95% (Non-condensing)
Max. Operating Altitude	1,000 m <sup>5</sup>
MV-LV AC Connections	Prewired and Pretested, No Internal Cabling Onsite
LV & MV Room Cooling	Smart Cooling without Air-across for Higher Availability
Communication	Modbus-TCP, Preconfigured with SmartACU
Standards Compliance	
IEC 62271-202, EN 50588-1, IEC 60076, IEC 62271-200, IEC 61439-1	

- 1: More detailed AC power of STS, please refer to the de-rating curve.  
2: Rated output voltage from 10 kV to 35 kV, more available upon request  
3: Extra expense needed for optional features which standard product doesn't contain, more options upon request.  
4: When ambient temperature ≥55°C, awning shall be equipped for STS on site by customer.  
5: For higher operating altitude, pls consult with Huawei.

# DCBOX-9/5-H0

## DC LV Panel



Electrical	
Max. Input Voltage	1,500 V
Nominal Input Voltage	1,200 V
Max. Branch Current for Battery Rack Side	321 A
Max. Branch Current for PCS Side	193 A
Number of DC Circuit Breaker	14
Max. Input Number of Battery Rack	9
Max. Input Number of PCS	5
Max. Convergence Capacity	5 x 193 A
Protection	
DC Overcurrent Protection	Yes
Environment	
Operating Temperature Range	-30°C ~ 60°C
Relative Humidity	0 ~ 100% (Non-condensing)
Max. Operating Altitude	4,000 m
General	
Cable Entries	Top in for PCS & Bottom in for Battery Rack
Dimensions (W x H x D)	2,040 x 1,415 x 975 mm
Weight (Without Smart PCS)	≤ 750 kg
DC Connector / AC Connector	OT Terminal
Protection Degree	IP55
Installation Options	Grounding

1 - The DCBOX can work with the LUNA2000-200KTL series models.



# Model: DTS-200K-D0 Distribution Transformer



Electrical	
AC Power	210 kVA@ 400 Vac / 4 kVA@ 110 Vac
Rated Input Voltage	800 Vac
Max. Input Current at Nominal Voltage	151.6 A
Rated Output Voltage	400V (3P) /110V (1P)
Rated Frequency	50 / 60 Hz
Transformer Type	Dry Type
Transformer Cooling Type	AF
Transformer Vectoring Group	Dyn11yn11
Transformer Tappings	± 2 x 2.5%
Transformer Winding	Al
Transformer Insulation Class	H
Transformer Impedance (at 145°C)	4% (±10%) @50Hz / 4.8% (±10%) @60Hz
Transformer No-load Loss	≤ 500 W (+15%)
Transformer Load Loss	≤ 3,044 W (+15%)
Cablings	
Number of outputs	Five MCCBs, each connected to two outputs
Cabling mode	Routed in and out from the bottom
Protection	
Protection Degree	IP 55
LV SPD	Type II
Transformer Protection	Transformer Temperature Protection
Environment	
Operating Temperature Range	- 30°C ~ 55°C
Relative Humidity	0% ~ 95% (Non-condensing)
Max. Operating Altitude	4,000 m
General	
Dimensions (W x H x D)	900 x 2,100 x 1,200 mm
Weight	< 1.3 t
Communication Mode	Dry Contacts
Cooling Type	Smart Cooling without Air-across for Higher Availability
Standards Compliance	
IEC 60076, IEC 61439	

# Model: SPPC2000

## Smart Power Plant Controller



SPPC2000



**POC PT/CT direct sampling**



**PV&ESS Synergy**



**Fast Power Response**



**Power Oscillation Damping**

Technical Specifications	SPPC2000-A01	SPPC2000-A02
<b>Device Management</b>		
Networking Mode	Active/Standby and Master-Slave Control Mode	
<b>Features</b>		
Active Power Control	System-level 30ms-40ms Dynamic Reactive Power Response	
Frequency Control (P-F)	P-F Curve Control	
Reactive Power Control (Q or PF)	Reactive Power Control with Dynamic or Fixed Q/PF Setpoints	
Voltage Control (Q-U)	Q-U Curve Control	
Smart Reactive Power Compensation	System Level Dynamic Reactive Power Response Based on Inverter/Converter	
Ramp Control (Power)	Control the Active/Reactive Power Up and Down Ramp Rates	
Cooperative Control of PV and ESS	Yes	
Power Oscillation Damping (POD)	Oscillation Suppression Range (0.1~2.5 Hz)	
Waveform Recording Function	Supports Instantaneous Value (0.5ms) and rms Value Recording of Current and Voltage	
Time Synchronization Function	Supports IRIGB ( $\leq 1$ ms) and Other Time Synchronization Protocols (e.g., NTP)	
Breaker Status Acquisition and Control	Control Substations Disconnection and Connection	
Simulation Model	PSSE, DigSILENT, PSCAD	
PT/CT Sampling current	1A	5A
<b>Communication Interface</b>		
Ethernet	6 + 2	
Optical Ethernet	SFP x 2, 100 / 1,000 Mbps	
RS485	COM x 4	
Current/Voltage Sampling	6U + 6I	
CAN	2	
Communication Protocol	Modbus-TCP, IEC60870-5-104, GOOSE	
<b>Interaction</b>		
WEB	Yes	
HMI	Smart PV Management System / Smart Energy Management System	
<b>General</b>		
Dual Power Supply	AC: 90 V ~ 264 V, 47 Hz ~ 63 Hz, DC: 110 V $\pm$ 10%, 220 V $\pm$ 10%	
DC/AC Surge Arrester	Type II	
Dimensions (H x L x W)	1000 x 650 x 650 mm (Without Base)	
Weight	$\leq 80$ kg (Without Pallet and Optional Components)	
Operating Temperature Range	-25°C ~ 60°C	
Relative Humidity	0% ~ 100% (Non-condensing)	
Max. Operating Altitude	4,000 m	
Protection Degree	IP55	
Anti-corrosion Protection	C5-Medium	
Installation Options	Floor Mounting, Wall Mounting (Optional)	

Please confirm the available countries with Huawei Fusionsolar engineers

SOLAR.HUAWEI.COM

# Model: SmartACU2000D

## Smart Array Controller



With SmartPID2000 Module



### Smart

Support one-click commissioning  
Patented anti-PID module



### Simple

SmartPID2000 & Smartlogger3000B  
pre-installed with multiple interfaces



### Reliable

Industrial-level application  
and high reliability

### Technical Specifications

SmartLogger	SmartLogger3000B x 1
SmartModule1000A	Standard with 1
RS485	COM x 6, 1,200 / 2,400 / 4,800 / 9,600 / 19,200 / 115,200 bps
Number of MBUS Module <sup>1</sup>	2
Number of SmartPID2000	2
Switch with 4*SFP and 8*100 / 1,000 Mbps	2
Electrical	
AC Input Voltage for Cabinet	100 V ~ 240 V, L / N (L)+ PE
AC Input Voltage for MBUS	380 V ~ 800 V, 3Ph
AC Input Voltage for PID	380 V ~ 800 V, 3Ph + FE (Functional Earth)
AC Input Frequency	50 Hz / 60 Hz
Power Supply	Standard: 12 V DC
Environment	
Operating Temperature Range	- 40°C ~ 60°C
Relative Humidity	0% ~ 100% (Non-condensing)
Max. Operating Altitude	4,000 m
Mechanical	
Dimensions (W x H x D)	880mm×770mm×369mm
Weight	66 kg
Protection Degree	IP65
Installation Options	Wall Mounting, Rack Mounting, Pole Mounting
Cable Entries	Bottom in & out
Maintenance	Front

1: Compatible with communication mode of PLC (Power Line Communication).

# Model: SmartPID2000 Module Inside Smart Array Controller



The SmartPID2000 Module is installed in the SmartACU2000D cabinet and support continuous DC & AC insulation detection with optional Smart IMD.



### Smart

Data read and software upgrade through USB or the embedded Web



### Safe & Reliable

Inject LV AC voltage to earth  
Continuous DC & AC insulation detection with optional Smart IMD

## SmartPID2000 Solution Diagram

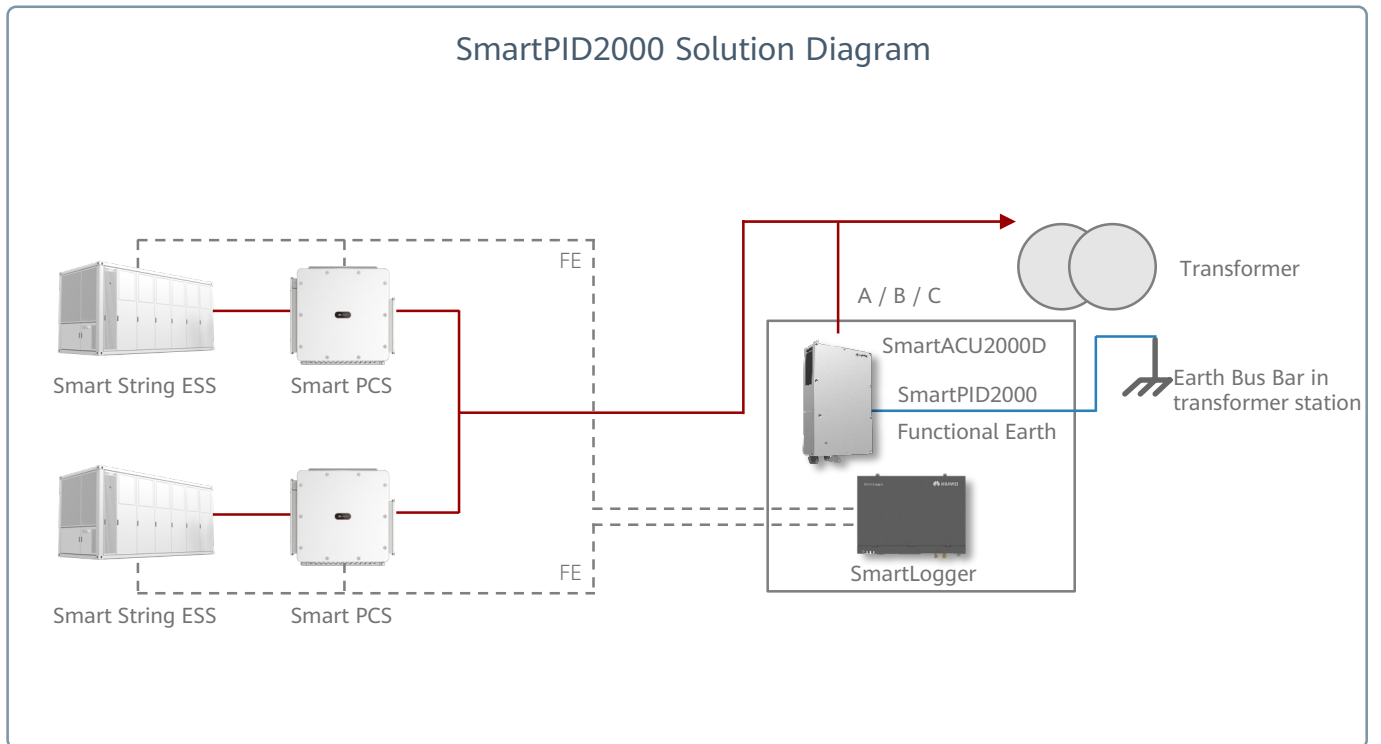

Note:  
1 - The SmartPID module could ONLY be deployed in utility scenarios where the LV sides of transformer stations are IT system.  
2 - The SmartPID module must work with FusionSolar SmartLoggers and smart PV controllers / smart PCS.

# Model: SmartEMS2000

## Smart Energy Management System(Preliminary)



### Comprehensive management

Multi-level refined management  
Second-level performance curve drawing



### Efficient collaboration

Power generation plan curve  
PV&ESS synergy optimization



### Intelligent diagnosis

Full-link multi-dimensional plant diagnosis  
Cell/module fault pre-warning



### Safe and reliable

IEC62443 certification.  
99.99% availability

EMS cabinet		
Dimensions (W x D x H)	600mm×2200mm×1200mm (47u)	
Operating Temperature Range	5 - 30°C	
Protection Degree	IP20	
Weight	Net weight approx. 210 kg, full configuration approx. 600 kg	
AC Input Voltage	200V~240V	
Rated Frequency	50 / 60 Hz	
Max. Operating Altitude	4,000 m	
Server		
Model	TaiShan 200 (2280)	
Dimensions (W x D x H)	482.6mm*790mm*88.9mm. (2U)	
CPU	2*Kunpeng 920 - 48core @2.6GHz	
Database	GaussDB	
Operating system	EulerOS	
Memory	4*64G	
Hard Disk	8*1.92T SATA SSD	
Fans	Four hot-swappable fans in N+1 redundancy	
External Interface	8*GE	
Power supply	2 x 900 W, 1+1 Redundancy	
Weight	Approx. 30 kg	
Certification	CCC/CE, etc.	
Switches		
Model	CloudEngine S5735-S24ST4XE-V2	CloudEngine S5735-S24T4XE-V2
Dimensions (W x D x H)	420mm*442mm*43.6mm (1U)	420mm*442mm*43.6mm (1U)
Weight	4.95 kg	4.34 kg
Memory	2 GB	2 GB
Power Supply	2*80W, 1+1 redundancy	2 x 80 W, 1+1 redundancy
Interface	Eight gigabit electrical ports, four 10GE optical ports, and 24 gigabit optical ports	24 GE electrical ports and 4 10GE optical ports
Rated Voltage	100V AC~240V AC; 50/60Hz	100V AC~240V AC; 50/60Hz
Certification	CE/VCCI, etc.	CE/VCCI, etc.

\*EMS will be available in Q1,25

# Network Applications

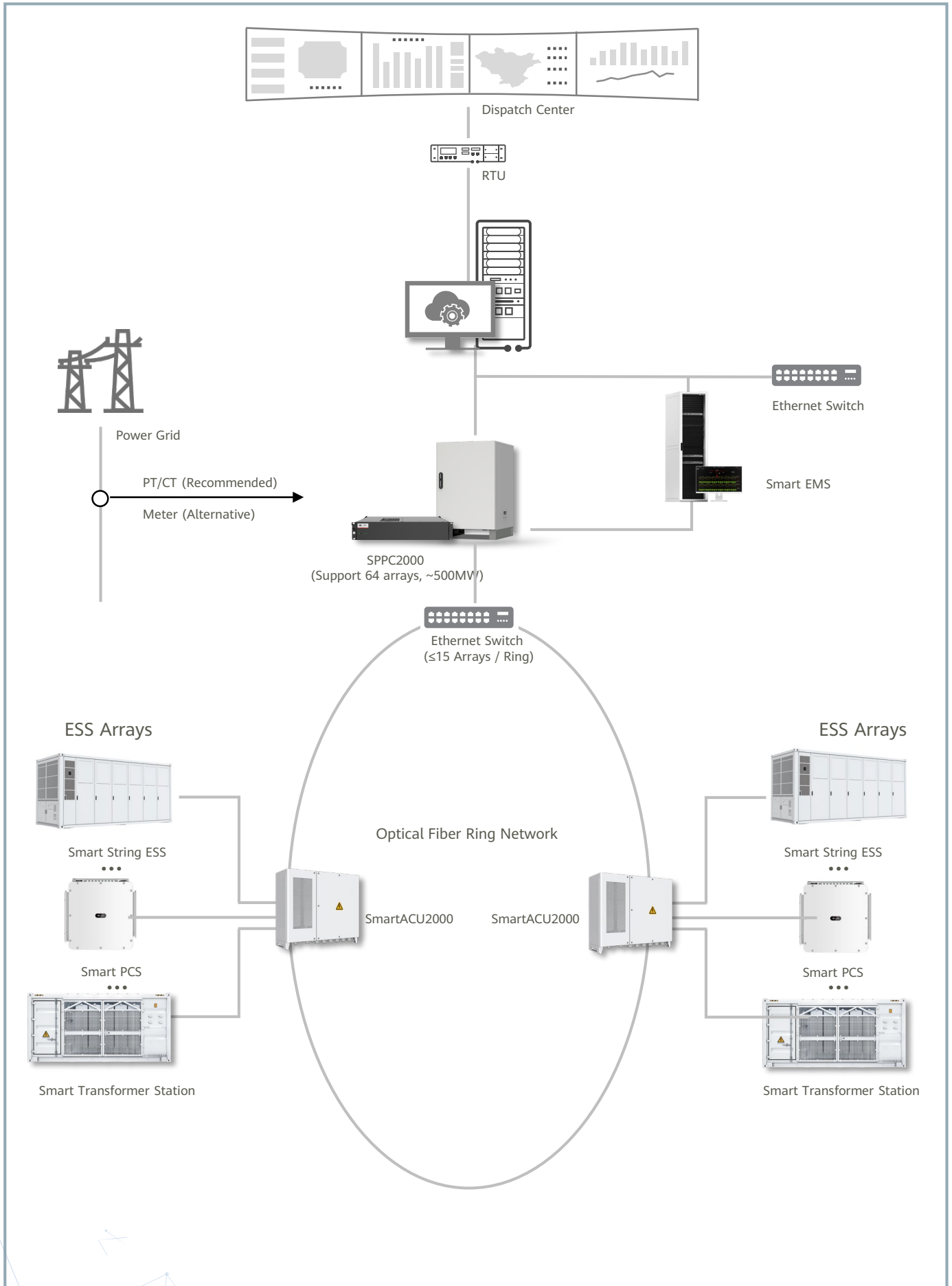

\*For details about the project configuration and sales area, contact Huawei engineers.  
SPPC does not support the PV & ESS low-voltage AC coupling solution.

# Smart PV Plant Management System



**Refined Management**



**Efficient O&M**



**Compatible with 3<sup>rd</sup> party system**

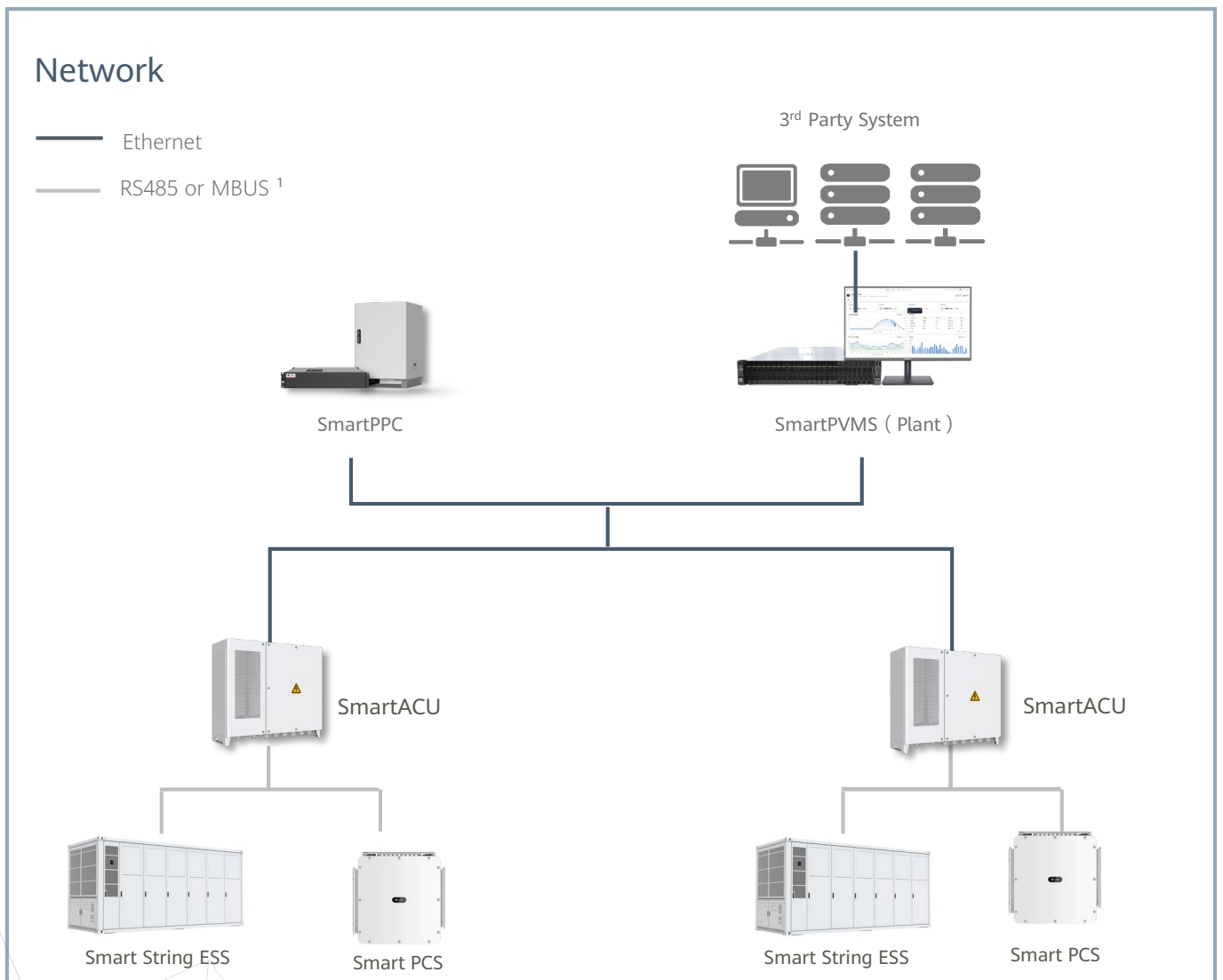

<sup>1</sup> - Compatible with communication mode of PLC (Power Line Communication).

# Smart PV Plant Management System

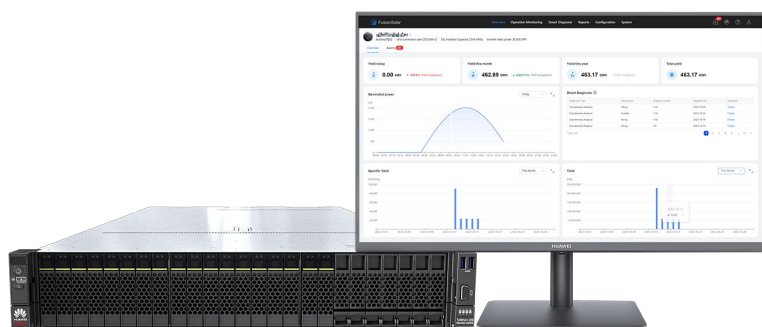

Server	Standard Version	Premium Version
<b>Technical Specifications</b>		
Model	TaiShan200 2280	TaiShan200 2280
Form Factor	2U rack server	2U rack server
CPU	2*Kunpeng 920-48core@2.6GHz	2xKunpeng 920-48core@2.6GHz
Memory	2*32GB	4*32GB
Internal Storage	2*1920GB	18*1920GB
Operating System	Euler OS	Euler OS
Database	Gauss DB	Gauss DB
Network Ports	8*GE	8*GE
Power Supply	2 hot-swappable PSUs, 1+1 redundancy	2 hot-swappable PSUs, 1+1 redundancy
Voltage	110/220 Vac	
Fan Modules	4 hot-swappable fan modules, N+1 redundancy	4 hot-swappable fan modules, N+1 redundancy
Operating Temperature	5°C ~ 40°C	5°C ~ 40°C
Dimensions (H x W x D)	86.1 x 447 x 790 mm	86.1 x 447 x 790 mm
Weight	27 kg	28 kg
<b>Standards Compliance</b>		
CCC CQC RCM VCCI FCC&IC-SDoC CE-SDoC CB+NRTL, etc.		



# Success Cases



## 400 MW PV + 1.3 GWh BESS

World's largest microgrid ESS plant

100% renewable energy  
World's first GW-level grid-forming PV & ESS plant  
GW-level black start and continuous fault traversal

COD: 2023

Location: Saudi Arabia



## 100MW PV + 200MWh BESS

Largest smart string energy storage plant in China

"String Energy Storage + Cloud BMS"  
Introduce the hybrid business model of "peak-valley price difference + leasing"

COD: Dec, 2022

Location: Hubei, China

# Success Case



## 25MW PV + 50MWh BESS

First Large Scale String Inverter + String Energy Storage Demonstration Project in Hainan

More than 174 million kWh of clean energy provided to Wenchang and Hainan power grids annually

COD: Apr, 2022

Location: Hainan, China



## 115MW PV + 146MWh BESS

Spinning Reserve, Frequency Regulation

One-cluster-one-management, constant power output for a longer time, achieving higher frequency modulation benefits

Automatic SOC calibration greatly reduces O&M costs

COD: Nov, 2022



Location: Singapore



Copyright © Huawei Technologies Co., Ltd. 2024. All rights reserved.

No part of this document may be reproduced or transmitted in any form or by any means without prior written consent of Huawei Technologies Co., Ltd.

#### Trademark Notice

 , HUAWEI, and  are trademarks or registered trademarks of Huawei Technologies Co., Ltd. Other trademarks, product, service and company names mentioned are the property of their respective owners.

#### General Disclaimer

The information in this document may contain predictive statements including, without limitation, statements regarding the future financial and operating results, future product portfolio, new technology, etc. There are a number of factors that could cause actual results and developments to differ materially from those expressed or implied in the predictive statements. Therefore, such information is provided for reference purpose only and constitutes neither an offer nor an acceptance. Huawei may change the information at any time without notice.

#### HUAWEI TECHNOLOGIES CO., LTD.

Huawei Industrial Base, Bantian Longgang  
Shenzhen 518129, P.R. China  
Tel: 400-822-9999  
Solar.Huawei.com

The text and figures reflect the current technical state at the time of printing. Subject to technical changes. Errors and omissions excepted. Huawei assumes no liability for mistakes or printing errors. For more information, please visit [solar.huawei.com](http://solar.huawei.com). Version No.:01-(202304)